

# 我就是鐵牛 I am OX.

## CNC立橫兩用加工中心機 VERTICAL / HORIZONTAL CNC MILLING MACHINE

Z: 600mm  
A: 500mm  
Y: 600mm  
X: 1300mm



**OX-1360HK**



**千誠機械股份有限公司**  
**CHIEN CHENS MACHINERY CO., LTD.**  
[www.oxmachine.com](http://www.oxmachine.com)



# 機台尺寸 Machine size

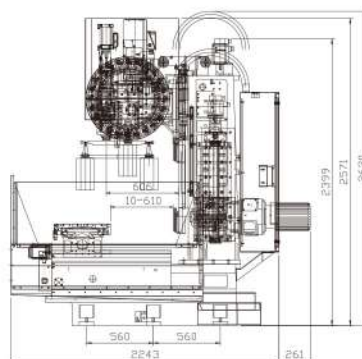
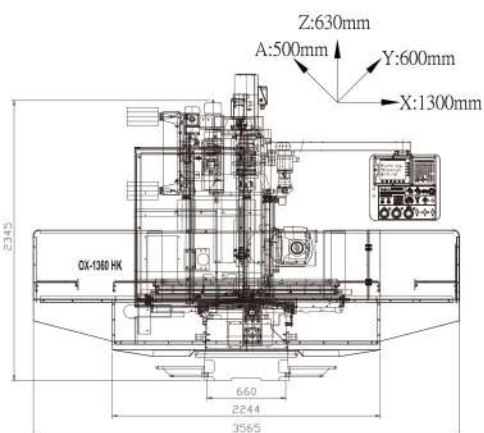
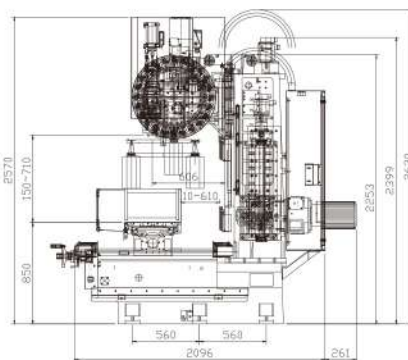
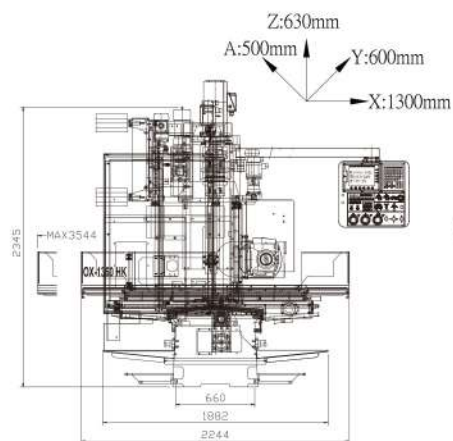

Z: 600mm  
A: 500mm  
Y: 600mm  
X: 1300mm



**OX-1360HK**

# 機台尺寸 Machine size

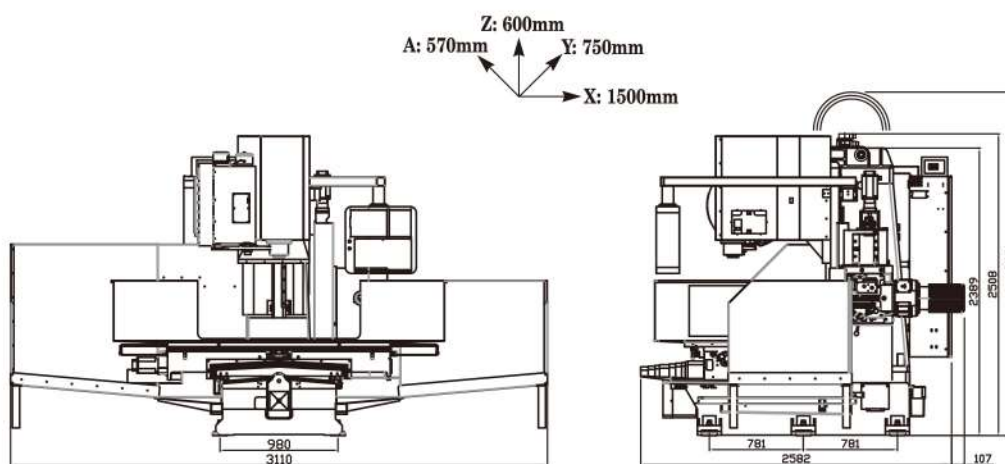
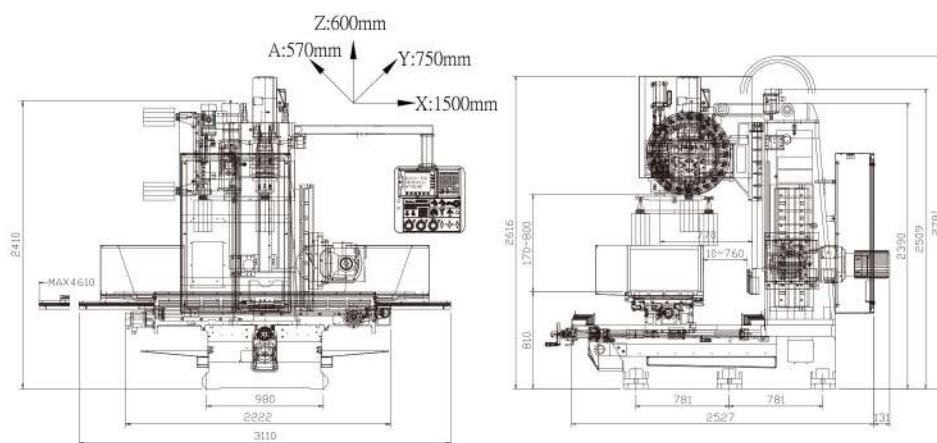

**OX-1575**

# 主軸扭矩圖 Spindle torque diagram

JSM-100-03-20

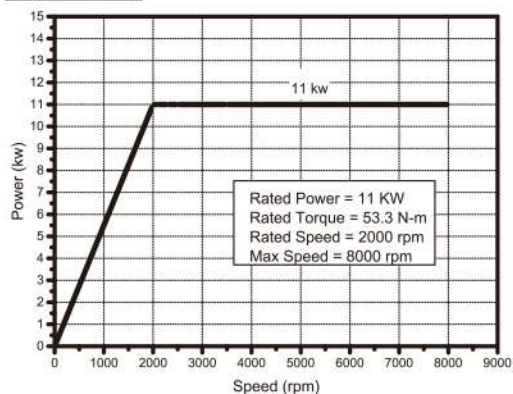

JSM-100-03-20

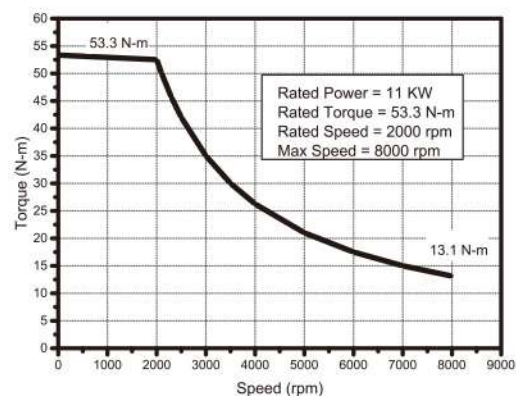

# 機台尺寸 Machine size

Z: 600mm  
Y: 600mm  
X: 1300mm

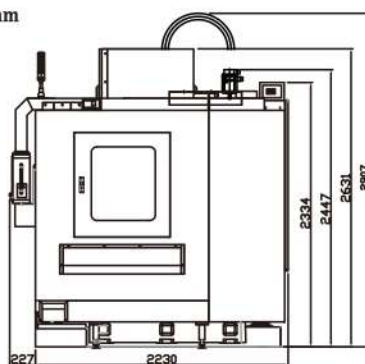
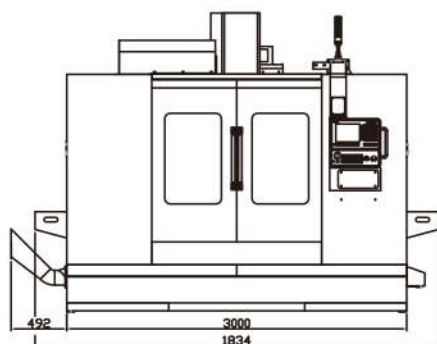

**OX-1360全罩板金**

# 老師傅的最愛-教導功能

Instruction-typed Function

## CNC+教導功能+傳統=3用

CNC + Instruction + Tradition = Tri - Use

### 四軸CNC控制 Four-axis CNC Control

#### 功能：

- 一般G/M碼操作
- 背景編輯
- 巨集程式功能
- 程式傳輸加工功能
- 多國語言
- 圖形模擬顯示
- 硬體自我診斷顯示
- MPG執行加工程式

#### Function:

- General G/M Code Operation
- Background Editing
- Program Function
- Program Transmission Function
- Multi-national Languages
- Pattern Simulated Display
- Hardware Self-diagnosis Display
- MPG Execute Program



### 教導功能 Instruction

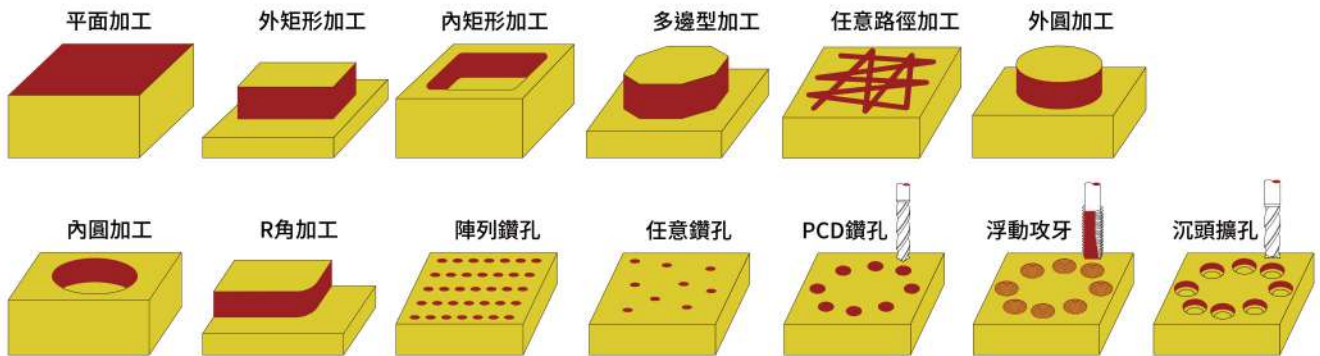

### 臥式切削機構

Horizontal Type Machining Structure

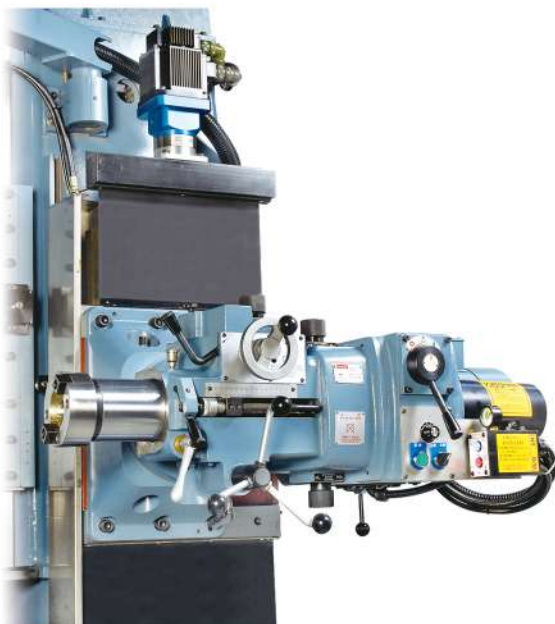

**HK** 砲塔式主軸(主軸可伸縮)  
HK Turret Type Spindle (Over Travel 140mm)



**H** 齒輪頭構造(主軸不可伸縮)  
H Gear Type Spindle (Six-Steps Gearbox)

機械規格/Specification			OX-1360	OX-1575
行程 Travel	三軸行程 X/Y/Z axis	mm	1300/600/600	1500/750/600
	主軸鼻端至工作台面 Spindle nose to table surface	mm	100~700	170~800
	主軸中心至立柱軌道面 Spindle center to column surface	mm	606	770
工作台 Table	工作台尺寸 Table size (L*W)	mm	1515*470	1850*650
	T型槽 T-slots(Width * No.)	mm	18*5	18*5
	工作台載重 Table load	kg	800	1000
主軸 Spindle	主軸 Spindle taper		BT-40	BT-40(BT-50)
	主軸轉速(皮帶式) Spindle speed (Belt)	rpm	8000	8000(6000)
馬達 Motor	主軸馬達 Spindle motor	kw	11	11
	伺服馬達 X/Y/Z/(A) Servo motor	kw	1/1/1/(1)	2/2/2/(1)
進給 Feed	快速進給 X/Y/Z/(A) Rapid feed rate	m/min	6/6/6/(1.2)	6/6/6(1.2)
	切削進給 X/Y/Z/(A) Cutting feed rate	m/min	5/5/5/(1)	5/5/5/(1)
	JOG進給 X/Y/Z/(A) JOG feed rate	m/min	4/4/4/(1)	4/4/4/(1)
刀庫 Magazine	最大刀具直徑 Max. tool dia./with adjacent tool	mm	ø78/ø150(鄰刀空)	ø78/ø150(鄰刀空)
	最大刀具重量 Max. tool weight	kgs	8	8
	最大刀具長度 Max. tool length	mm	250	250
	刀庫容量 Tool Capacity	T	24	24
其它 Others	定位精度 Position accuracy	mm	±0.008/300	±0.008/300
	重覆精度 Repeatability accuracy	mm	±0.005	±0.005
	氣壓需求 Pneumatic unit	kg/cm <sup>2</sup>	6	6
	電力需求 Power	kva	20	25
重量/尺寸 Weight/ Size	Floor space (L x W x H)	mm	Max3565*2504*2630	Max4610*2658*2781
	packing size (L x W x H)	mm	1882x 2400 x 2450	2250*2700*2520
	淨重/毛重 N.W./G.W.	kgs	4000/4150	5780/6000

※本型錄之規格,本公司保有隨時變更之權利,恕不另行通知。 We reserve the right to modify design without prior notice.

### 標準配件 Standard Accessories:

- 外掛式電子手輪 MPG Hand Wheel
- 自動潤滑系統 Auto Lubrication Pump
- 工作台半罩钣金 Table Enclosed Guard
- 切削液系統 Coolant Pump System
- 主軸吹氣 Spindle Air Blast
- 主軸油冷卻機 Spindle Oil Coolant
- 電器箱空調冷氣機 Electrical Cabinet Air Conditioner
- 自動斷電系統 Auto Power Off
- 三色警示燈 Alarm Lights
- LED工作燈\*2 LED Working Light\*2
- 水平調整螺絲 Level Pads And Level Bolts
- 專用隨身碟 USB
- 工具箱及工具 Tool Box & Tools
- 保養操作手冊 Operation Manual

### 選擇附件 Optional Equipment:

- H臥式機構(齒輪頭) H Horizontal Type Machining Structure
- HK臥式機構(砲塔頭) HK Horizontal Type Machining Structure
- 傳統手輪\*2只(X,Y) Manual Hand Wheel \*2(X,Y)
- 冷風槍 Coolant Spear
- CNC旋轉分度盤 CNC Rotary Table
- 第四軸介面 Interface For CNC Rotary Table
- 變穩壓器 Transformer
- 油水分離機 Stainle Belt Type Oil Skimmer
- 外圍半罩钣金 Half Cover Enclosed Guard
- 全罩式钣金 Full Cover Enclosed Guard



## 千誠機械股份有限公司 CHIEN CHENS MACHINERY CO., LTD.

台灣桃園市中壢區福星六街60之2號  
No. 60-2, Fu Hsing 6th St., Chung Li Dist.,  
Tao Yuan City, Taiwan  
Tel: 886-3-462-6421 Fax: 886-3-462-7645  
E-mail: chienchens@hotmail.com.tw  
<https://www.oxmachine.com>

